

Type: T-A6 (260 mm - 365 mm)

TA-5 pedestal for raised floors with adjustable height from 260 mm to 365 mm, provided of bicomponent head with slip rubber on top.

Pedestals are composed by a cylindrical base element of 195 mm diameter for resting on the laying surface, an intermediate screw with a locking security system.

Technical Features

- The products are produced from recycled (PP) materials.
- Height range is 260 to 365 mm.
- This pedestal is comprised with base, head and slope and corrector
- Top-diameter 147 mm, surface area 170 cm² and wall thick 5 mm
- Bottom-diameter 195 mm, surface area 299 cm² and wall thick 5,5 mm
- Resistant to bad weather conditions, UV light, aging and most of cemical reaction

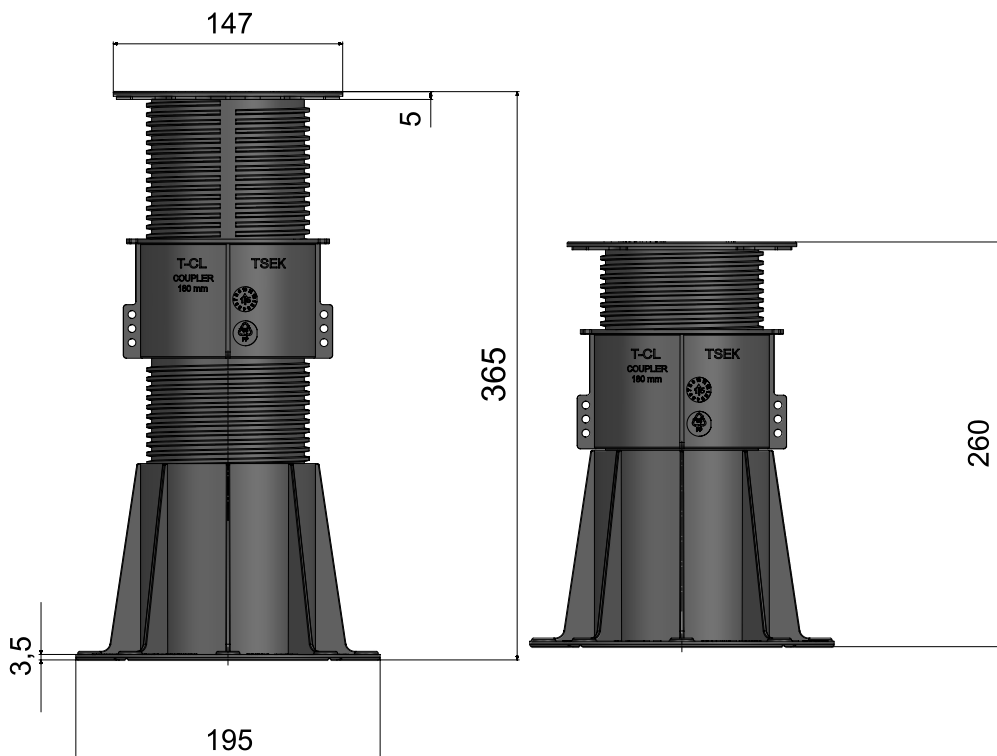

Test results

Position	Height (mm)	Load (daN)
1/1	265	1925
1/2	265	1540
1/4	265	962,5
1/1	360	1347,5
1/2	360	1078
1/4	360	673,75

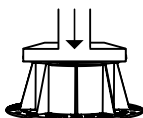

1/1: Load evenly applied across entirety of the load-bearing surface

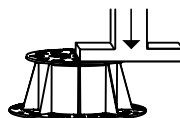

1/2: load applied to half of load-bearing surface.

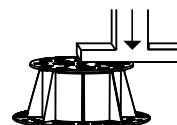

1/4: load applied to one quarter of the load-bearing surface.

1 daN = 1 kg / f = 2,23 lb / f

Type: T-A6 (260 mm - 365 mm)

Accessories



TA-S
Accuracy gasket, made from EPDM, has 1mm and 2mm thickness alternatives and made for avoiding calibration problems of tile pavements.



TS-C
Slope Correctors, sit under bottom pedestal, avoids all impacts from drain slopes.



T-P
Made of EPDM material, orthopedic floor pad helps to absorb all impact vibrations caused by bumpy luster surfaces.

TILE PAVING



TS-F
Fixed joint strips have alternatives of 3, 5, 7 and 9mm.



TS-T
Joint strips have a selection of 2, 4, 6 and 8mm thickness alternatives and it is 360 degrees turnable.



TS-A
Conical form joint strips are used for covering products that have angle on side lines.



TS-P
Plus shape formed joint strips can be sit in the middle of pedestal and have 4mms thickness.

LATH PAVING



TA-W
Firstly, regarding to anticipated distance in terms of reference, Carcass Assembly Equipment is assembled on carcass with auxiliary screws.



TA-R
This type of carcass assembly equipment is put every point on pedestal except central point.



TA-X
X formed Carcass Assembly Equipment does sit on top and central of the pedestal.



TA-P
Carcass Assembly Equipment is sit on the center hole of Pedestal.

Application

Adjustable pedestals KAROAPP PEDESTALS allow to regulate accurate and permanent height. Can support any type of ceramic or timber decking, stone, concrete paving or flag material, as well as fibreglass or metal grid panels.

Suitable for any kind of stable substrate, including applications directly over insulation panels.

Covering size	m ² / pcs.
30 x 30 cm	13,80
40 x 40 cm	7,80
30 x 60 cm	6,70
40 x 60 cm	5,20
50 x 50 cm	5,00
60 x 60 cm	3,50

www.karoapp.com.tr
www.gurbetciler.com.tr

info@karoapp.com.tr
info@gurbetciler.com.tr